

B.TECH.
(SEM. III) THEORY EXAMINATION 2018-19
MECHANICS OF SOLIDS

Time: 3 Hours

Total Marks: 70

Note: Attempt all Sections. If require any missing data; then choose suitably.

SECTION A

1. Attempt *all* questions in brief.

2 x 7 = 14

- a. Differentiate between the terms section modulus and flexural rigidity.
- b. What do you understand by autofrettage? Explain it in brief.
- c. Analytically differentiate between bending of straight and curved beam.
- d. Differentiate between strain energy and shear strain energy.
- e. What is the difference in analysis of closed and open coiled springs.
- f. Define shear center and its importance.
- g. Explain slenderness ratio and its importance in case of column.

SECTION B

2. Attempt any *three* of the following:

7 x 3 = 21

- a) A beam ABCDE is continuous over four supports and carries the loads shown in figure given below. Determine the values of the fixing moments at each support.

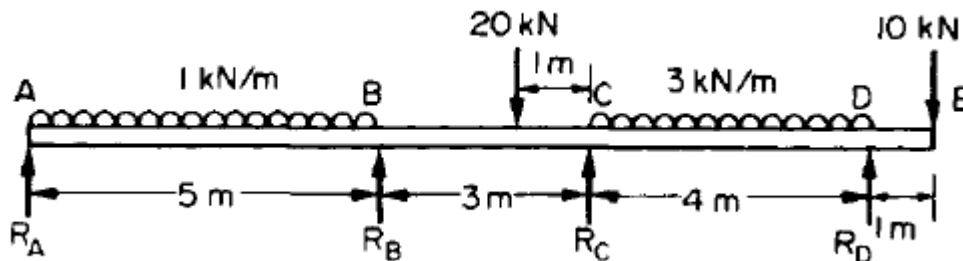

- b) Derive the differential equation of deflection curve.
- c) A close coiled helical spring is fixed at one end and subjected to axial twist at the other. When the spring is in use the axial torque varies from 0.75 N-m to 3 N-m, the working angular deflection between these torques being 35° . The spring is to be made from rod of circular section, the maximum permissible stress being 150 MN/m^2 . The mean diameter of the coils is eight times the rod diameter. Calculate the mean coil diameter, the number of turns and the wire diameter.
- d) The load to be carried by a lift may be dropped 10 cm on to the floor. The cage itself weighs 100 kg and is supported by 25 m of wire rope weighing 0.9 kg/m, consisting of 49 wires each 1.6 mm diameter. The maximum stress in the wire is limited to 90 N/mm^2 and E for the rope is 70000 N/mm^2 . Find the maximum load which can be carried.
- e) A timber beam 6 cm wide and 8 cm deep is to be reinforced by bolting on two steel flitches, each 6 cm by 5 mm in section in the following cases:
 - i. flitches attached symmetrically at top and bottom:

- ii. flitches attached symmetrically at the sides
 Take allowable timber stress as 8 N/mm^2 . What is the maximum stress in the steel in each case? Take $E_{\text{steel}} = 210 \text{ kN/mm}^2$, $E_{\text{timber}} = 14 \text{ kN/mm}^2$

SECTION C

3. Attempt any *one* part of the following: 7 x 1 = 7

- (a) A steel tube of 24 mm external diameter and 18 mm internal diameter encloses a copper rod 15 mm diameter to which it is rigidly attached at each end. If, at a temperature of 10°C there is no longitudinal stress, calculate the stresses in the tube and rod when the temperature is raised to 200°C .

$$E_{\text{steel}} = 210 \text{ kN/mm}^2 \quad E_{\text{copper}} = 210 \text{ kN/mm}^2$$

Coefficients of linear expansion:

$$\alpha_{\text{steel}} = 11 \times 10^{-6} / ^\circ\text{C} \quad \alpha_{\text{copper}} = 11 \times 10^{-6} / ^\circ\text{C}$$

- (b) A small block is 40 mm long, 30 mm high and 5 mm in thick. It is subjected to uniformly distributed tensile forces having the resultant values in N shown in figure. Compute the stress components developed along the diagonal AC.

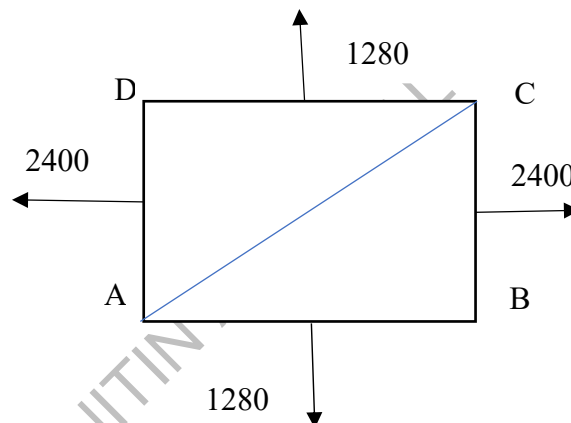

4. Attempt any *one* part of the following: 7 x 1 = 7

- (a) A solid circular shaft of length 3 m and diameter of 50 mm rotates at 1200 rpm by a 400 HP electric motor at its middle. It drives two machines of 150 HP and 250 HP at left and right ends of the shaft, respectively. Determine the maximum shear stress and relative displacement of the two ends of the shaft. Take $G = 85 \text{ GPa}$

- (b) Determine the deflection of the beam at midpoint for the beam loading system shown in the figure given below.

Take: $E = 200 \text{ GN/m}^2$ and $I = 83 \times 10^6 \text{ m}^4$.

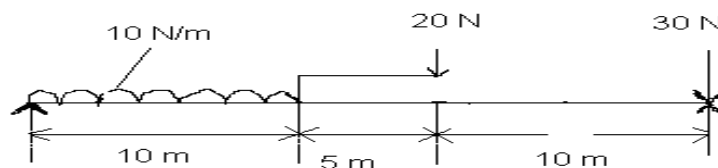

5. Attempt any *one* part of the following: 7 x 1 = 7

- (a) A short column is of hollow circular section, the center of the inside hole being 6 mm eccentric to that of the outside. The outside diameter is 96 mm and the

inside 48 mm The line of action of the load intersects the cross-section at a point in line with the two centers What are the limiting position of the load for there to be no tensile stress set up?

- (b) Derive the relation to find deflection induced in the open coiled helical spring subjected to axial Torque.

6. Attempt any *one* part of the following:

7 x 1 = 7

- (a) The cylinder for a hydraulic press has an inside diameter of 300 mm. Determine the wall thickness required if the cylinder is to withstand an internal pressure of 60 MPa without exceeding a shearing stress of 90 MPa.
- (b) In an experiment on a thick cylinder of 100 mm external diameter and 50 mm internal diameter the hoop and longitudinal strains as measured by strain gauges applied to the outer surface of the cylinder were 240×10^{-6} and 60×10^{-6} respectively, for an internal pressure of 90 MN/m², the external pressure being zero.

Determine the actual hoop and longitudinal stresses present in the cylinder if $E = 208 \text{ GN/m}^2$ and $\nu = 0.29$. Compare the hoop stress value so obtained with the theoretical value given by the Lamé equations.

7. Attempt any *one* part of the following:

7 x 1 = 7

- (a) A 75 mm x 75 mm x 12 mm angle is used as a cantilever with the face AB horizontal as shown in figure. A vertical load of 3 kN is applied at the tip of the cantilever which is 1 m long. Determine the stresses at A, B and C.

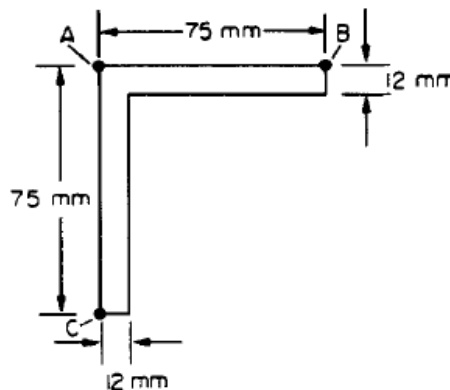

- (b) The bending moment acting on the curved beam with a rectangular cross-section is $M = 8 \text{ kN-m}$. Calculate the bending stress at point B.

