

B. TECH.
(SEM VI) THEORY EXAMINATION 2022-23
CONTROL SYSTEM

Time: 3 Hours

Total Marks: 100

Note: Attempt all Sections. If require any missing data; then choose suitably.

SECTION A

1. Attempt all questions in brief.

2 x 10 = 20

- (a) Explain Eigen Vector.
- (b) Define damping ratio.
- (c) Differentiate between open loop system and closed loop system
- (d) Explain resonant peak and resonant frequency
- (e) Explain the Incremental Encoder
- (f) What is servomechanism?
- (g) Define transfer function.
- (h) Explain static velocity error constant and static acceleration error constant
- (i) What is characteristic equation?
- (j) Explain characteristics of an ideal control system.

SECTION B

2. Attempt any three of the following:

10 x 3 = 30

- (a) Find the transfer function Y_8/Y_1 of the signal flow graph shown in Fig. 1

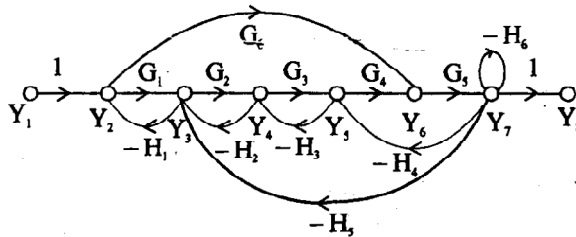

Fig. 1

- (b) A linear time invariant system is characterized by the state variable model. Examine the controllability and observability of the system

$$A = \begin{bmatrix} 0 & 0 & 0 \\ 1 & 0 & -3 \\ 0 & 1 & -4 \end{bmatrix}, \quad B = \begin{bmatrix} 40 \\ 10 \\ 0 \end{bmatrix}, \quad C = [0 \quad 0 \quad 1]$$

- (c) Explain steady state error in detail. Derive its expression for step and ramp inputs in type 1 systems.
- (d) Discuss the effect of adding a zero to the forward path in detail.
- (e) Explain Routh Hurwitz stability criterion. Using this method check the stability of the system whose characteristic equation is $2s^5 + s^4 + 6s^3 + 3s^2 + s + 1 = 0$.

SECTION C

3. Attempt any one part of the following:

10 x 1 = 10

- (a) Discuss the effect of feedback on following:
 - (i) Stability
 - (ii) Sensitivity
 - (iii) Overall Gain.

- (b) Determine the transfer function $Y_2(s)/F(s)$ of the system shown in Fig. 2

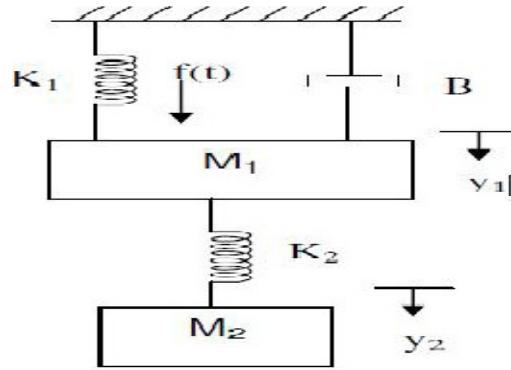

Fig. 2

4. Attempt any one part of the following: 10 x 1 = 10

- (a) Find the state transition matrix of a control system whose state equation is given by:

$$\begin{bmatrix} \dot{x}_1 \\ \dot{x}_2 \end{bmatrix} = \begin{bmatrix} 0 & 1 \\ -2 & -3 \end{bmatrix} \begin{bmatrix} x_1 \\ x_2 \end{bmatrix};$$

- (b) Construct the state model for a system characterized by the differential equation:

$$\frac{d^3y}{dt^3} + 6\frac{d^2y}{dt^2} + 11\frac{dy}{dt} + 6y = 4$$

Give the block diagram representation of the state model

5. Attempt any one part of the following: 10 x 1 = 10

- (a) Derive the expressions for peak overshoot, rise time and peak time of a second order system subjected to unit step input.
 (b) Derive the time response of a second order system subjected to unit step input.

6. Attempt any one part of the following: 10 x 1 = 10

- (a) Draw the Bode Plot for the transfer function $G(s)$. From the bode plot determine-
 (i) Phase crossover frequency
 (ii) Gain crossover frequency
 (iii) Gain Margin
 (iv) Phase Margin

$$G(s) = \frac{36(1+0.2s)}{s^2(1+0.05s)(1+0.01s)}$$

- (b) Sketch the polar plot for $G(s) = \frac{20}{s(s+1)(s+2)}$

7. Attempt any one part of the following: 10 x 1 = 10

- (a) Write a short note on
 (i) Bounded input and bounded output stability
 (ii) Zero input and asymptotic stability
 (b) Sketch the root locus plot for $G(s) = \frac{K(s+1)}{s^2(s+3.6)}$ and $H(s) = 1$.