

B.Tech.
(SEM VII) THEORY EXAMINATION 2022-23
MATHEMATICAL MODELING OF MANUFACTURING PROCESSES

Time: 3 Hours

Total Marks: 100

Note: Attempt all Sections. If you require any missing data, then choose suitably.

SECTION A

1. Attempt all questions in brief.

2*10 = 20

- (a) How are physics-based models used in the manufacturing industry?
- (b) Explain the statement: "Tool life is a random variable."
- (c) What is strain hardening? How might it be used in manufacturing?
- (d) Define Centre-line Feeding Resistance (CFR)?
- (e) In what ways is a thermit weld similar to the production of a casting?
- (f) What is the role of thermoplastic material in P/M injection moulding?
- (g) Classify additive manufacturing processes.
- (h) Why might chipless machining processes have greater importance in the future?
- (i) What are microalloyed steels? Where are they used?
- (j) Mention the factors on which the suitability of the casting operation for a given material depends.

SECTION B

2. Attempt any three of the following:

10*3 = 30

- (a) Explain the different methods that can be used to control the properties of engineering materials to make the materials suitable for a given application.
- (b) Draw comparison chart to explain clearly the difference between orthogonal cutting and oblique cutting.
- (c) Explain the various forming operations used in manufacturing processes.
- (d) Two gating designs for a mould of 50 cm × 25 cm × 15 cm are shown in fig below. The cross-sectional area of the gate is 5 cm². Determine the filling time for both the designs.

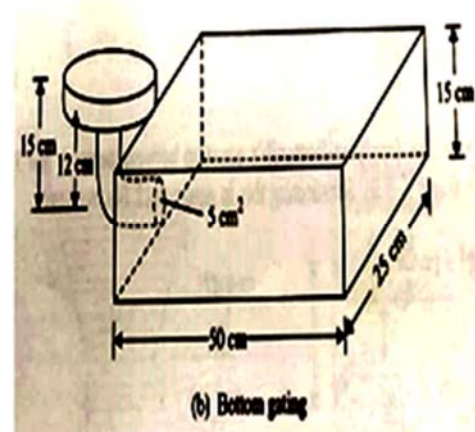
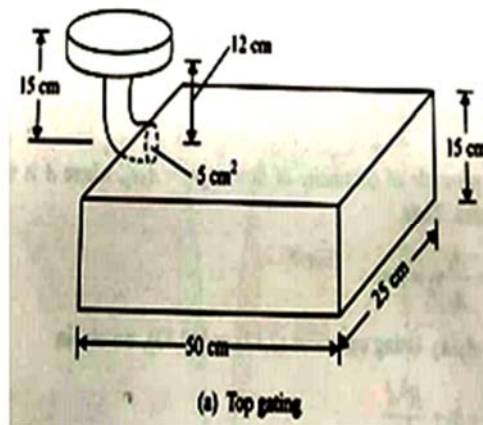

- (e) Explain with the help of a TTT diagram, how can we achieve different phases of plain carbon steel by changing only the rate of cooling.

SECTION C

3. **Attempt any one part of the following:** **10*1 = 10**
- (a) Briefly explain how heat treatment process affects the microstructure of metal and its alloy.
- (b) Explain ceramic materials and processing procedures.
4. **Attempt any one part of the following:** **10 *1 = 10**
- (a) During an orthogonal machining operation on mild steel, the results obtained are
- $t_1 = 0.25 \text{ mm}$ $t_2 = 0.75 \text{ mm}$ $w = 2.5 \text{ mm}$,
 $\alpha = 0^\circ$ $F_c = 950 \text{ N}$ $F_T = 475 \text{ N}$.
- (i) Determine the coefficient of friction between the tool and the chip.
- (ii) Determine the ultimate shear stress of the work material.
- (b) Explain the working of Abrasive Jet Machining with the help of a neat sketch. What are its advantages and limitations?
5. **Attempt any one part of the following:** **10*1 = 10**
- (a) What is fusion welding? Explain the important factors governing a fusion welding process.
- (b) Explain the modes of metal transfer in arc welding clearly showing the types of metal transfer.
6. **Attempt any one part of the following:** **10*1 = 10**
- (a) What is the principle of powder metallurgy? Explain in detail the basic steps involved in the manufacture of product by powder metallurgy technique.
- (b) Bring out the advantages of additive manufacturing technique. Mention some of its applications.
7. **Attempt any one part of the following:** **10*1 = 10**
- (a) Explain in detail the role of mathematical modeling in problem solving.
- (b) Briefly show how materials are plastically deformed and how residual stresses are removed if it being stored during plastic deformation.